

## PT-500-WB, 510-WB, 511-WB, 520-WB and 521-WB, 2-1/2 GALLON PRESSURE TANK (NON A.S.M.E.) WATERBORNE COMPATIBLE

**IMPORTANT:** Read and follow all instructions and SAFETY PRECAUTIONS before using this equipment. Retain for future reference.

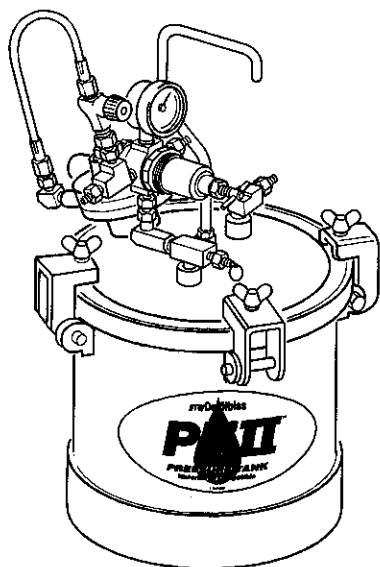

### DESCRIPTION

Model PT pressure tanks are designed as a pressure container to supply liquid material at a constant preset pressure up to a maximum of 80 PSI. All models include stainless steel wetted parts, a stainless steel lid and polyethylene liner, allowing use with waterborne materials. All models are for light to medium duty use only.

### Models:

**PT-500-WB:** No regulation, air inlet/outlet, fluid outlet, safety valve

**PT-510-WB:** Single regulation (fluid), air inlet/outlet, fluid outlet, safety valve

**PT-511-WB:** Dual regulation (air and fluid), otherwise same as PT-510-WB

**PT-520-WB:** Single regulation (fluid), air driven agitator assembly, fluid outlet, safety valve

**PT-521-WB:** Dual regulation (air and fluid), otherwise same as PT-520-WB

### WARNING

Halogenated hydrocarbon solvents - for example: 1,1, 1- trichloroethane and methylene chloride - can chemically react with aluminum, zinc plating or galvanized materials. If this reaction occurs within an enclosed container such as this pressure feed tank, the tank may explode. Do not use halogenated solvents with PT type pressure tanks. Any contact of these materials and halogenated solvents within the tank must be avoided.

Do not use PT (Non-ASME) pressure tanks over 15 PSI when using flammable materials. NFPA-33-95, Chapter 6-5.5 specifies only ASME code tanks can be used with flammable materials at pressures greater than 15 PSI.

### WARNING

Air pressure loads that are higher than design loads, or changes to the pressure feed tank can cause the tank to rupture or explode.

- A safety valve protects the tank from over pressurization. During each use pull the ring on the safety valve to make sure it operates freely and relieves air pressure. If the valve is stuck, does not operate freely, or does not relieve air pressure, it must be replaced. Do not eliminate, make adjustments or substitutions to this valve.

- Changes to the air tank will weaken it. Never drill into, weld or change the tank in any way.

- The maximum working pressure of this tank is 80 psi.

### SPECIFICATIONS

Tank Size:	2-1/2 gal (actual capacity is 2.76 gal)
Height:	9-9/16", (10-1/2" to top of lid)
Maximum Working Pressure (MWP):	80 psi
Air Motor Consumption:	3-6 CFM at 60 psi
Maximum Agitator Air Inlet Pressure:	100 psi
Air Inlet Size:	1/4" NPS (M)
Fluid Outlet Size:	3/8" NPS (M)
Tank Net Weight:	
PT-500-WB	20 lbs.
PT-510-WB	22-1/2 lbs.
PT-511-WB	24 lbs.
PT-520-WB	27 lbs.
PT-521-WB	28-1/2 lbs.

### MATERIALS OF CONSTRUCTION - WETTED PARTS

316 S.S. - Fluid Tube, lid bushing, outlet elbow and fitting; 303 S.S. - Agitator shaft (agitated models); molded nylon propeller (agitated models); polyethylene liner.

### NON-WETTED PARTS:

Zinc plated carbon steel tank; #304 stainless steel, electro- polished lid.

### PT-418 AIR MOTOR DRIVEN AGITATOR

The agitator utilizes an air driven motor to turn the agitator shaft to which a propeller is attached. The rotation of the propeller mixes materials which have a tendency to separate or settle quickly. Material agitation may be performed at the same time material is being sprayed without any adverse effect. The air motor is powerful and smooth running. An air adjusting valve is included to control the speed of the agitator. The air motor requires low air consumption, approximately 3-6 C.F.M. at 60 P.S.I. (Max. input air pressure 100 P.S.I.)

### INSTALLATION

Mix and prepare material to be used according to manufacturer's instructions. Strain material through a fine mesh screen (60 or 90 mesh) to remove all foreign matter which is likely to enter and clog material passages.

1. Always relieve all air pressure in the tank. Pull the ring on the safety valve until pressure bleeds down.
2. Loosen thumb screws, tip lid clamps back and remove lid assembly.

## SAFETY PRECAUTIONS

This manual contains information that is important for you to know and understand. This information relates to USER SAFETY and PREVENTING EQUIPMENT PROBLEMS. To help you recognize this information, we use the following symbols. Please pay particular attention to these sections.

CAUTION

Important information that tells how to prevent damage to equipment, or how to avoid a situation that may cause minor injury.

WARNING

Important safety information - A hazard that may cause serious injury or loss of life.

## Note

Information that you should pay special attention to.

## INSTALLATION (Continued)

3. Pour material into the tank. See accessories for disposable tank liners. A one gallon container may also be used by cutting 3/16" off end of fluid tube at an angle.
4. Replace the lid assembly and tighten clamps and thumb screws securely.
5. If possible, the air supply line should pass through an air filter/regulator to filter dirt from air and remove entrained water and oil. See Accessories for filters available. Connect the air supply hose to the air inlet fitting on tank regulator.
6. Connect the atomization air hose to the air outlet fitting which is directly opposite air inlet fitting.
7. Connect material hose to the fluid outlet fitting.
8. See Figure 1 for a typical hookup.

## Note

See Pg. 4 for air and fluid hook-up information on the tank.

Figure 1

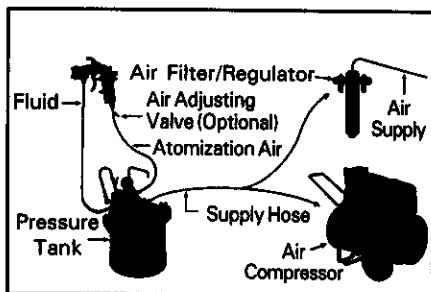

## OPERATION

1. Turn on the air supply.
2. Turn T-Handle adjusting screw clockwise on the tank regulator to increase material pressure: turn it counter clockwise to decrease pressure. Maximum tank pressure is 80 PSI.
3. For tank with air motor agitator, turn the knob of the air adjusting valve (9) counterclockwise to set the desired agitator speed. Operate the agitator at the minimum speed required to keep the material thoroughly mixed. Do not over-agitate the material. Air bubbles may form in the material, causing a poor finish.

4. Atomization air for the spray gun can be adjusted at the gun by means of an air adjusting valve (P-H-5516) or, with the additional air regulator provided with "dual regulation" tank models (PT-511-WB or PT-521-WB).
5. See Spray Gun instructions for operation of the gun.

CAUTION

If using an air quick disconnect (Q.D.) at the inlet to the regulator at the pressure tank, **do not** disconnect the Q.D. while the tank is pressurized, unless the ball valve is closed. Doing so will allow tank pressure to quickly relieve, and can potentially pull paint back through the air regulator and air motor, depending upon the liquid level in the tank. Tank pressure should always be relieved by turning the regulator fully counterclockwise, or pulling the safety valve ring.

REPLACEMENT OF PARTS  
(Air Motor Assembly, See Page 5)

Do not pry front plate (39) or end plate (45) from air motor body (42) with a screwdriver; this will dent the surface of the plates and body causing leaks. A puller tool should be used to remove the plate from the motor body while maintaining the position of the shaft. Holes must be drilled for dowel pins (41) after assembling front plate (39) on new body (42) for alignment of parts. Always install new end plate gaskets (40) when re-assembling air motor.

## PREVENTIVE MAINTENANCE

## To Clean Equipment:

1. If tank is equipped with agitator, turn off air to agitator first. This will prevent the possibility of paint contamination of the agitator air motor.
2. Turn off the main air supply to the tank.

3. Turn T-handle adjusting screw on tank regulator counterclockwise until no spring tension is felt.
4. Relieve all pressure from the tank by pulling the ring on the safety valve until the pressure bleeds down.
5. Loosen thumb screws, tip clamps back and tip tank lid to one side.
6. Loosen spray gun air cap retaining ring about three turns.
7. Turn on the air supply to spray gun.
8. Place cloth over air cap on the gun and pull trigger. This will force material back through the hose, into the tank.
9. Empty and clean tank and parts which come in contact with material. Use a suitable cleaning material.
10. Pour cleaning material into the tank.
11. Replace lid and tighten thumb screws and clamps.
12. Spray until clean solution appears.
13. Repeat steps 5 through 8.

Keep the safety valve clean at all times.

## Air Motor Assembly

CAUTION

Failure to properly lubricate the air motor will result in premature motor failure and will void warranty.

Lubricate air motor daily by adding 4 or 5 drops of SAE 10 weight oil into air inlet fitting.

Clean the agitator shaft (53, Pg. 5) and the propeller (55) at the end of each day. Occasionally remove and clean the muffler strainer felt (59) or replace, if necessary.

## SERVICE CHECKS

Condition	Cause	Correction
Air escaping from port on regulator cap.	Broken or damaged diaphragm.	Replace diaphragm.
Pressure creepage registered on gauge.	Dirty or worn valve seat in regulator.	Clean or replace valve seat.
Material tends to settle out rapidly.	Not enough agitation of material.	Increase agitation.
Air bubbles form in material.	Material being over-agitated.	Slow down agitator speed. Optional QMS-79 propeller (see ries) can be used to reduce the agitation.
Air leakage at agitator seal assembly.	Defective seal assembly (49).	Replace (49).
Paint getting into bearing assembly of agitator.	Paint level in tank too high. Paint being over-agitated. Defective seal assembly (49).	Fill tank 2-3" below rim. Slow down agitator speed. Replace (49).
Fluid or air leak at lid gasket.	Defective lid gasket Thumb screws not tight.	Replace. Tighten.
Air motor siezed. A. If agitator shaft does not turn by hand. B. If agitator shaft turns freely, check air motor.	Damaged seal assembly (49). Vanes (43) blackened/chipped at outer edges due to lack of oil.	Replace (49). Replace with Repair Kit KK-5C refer to air motor agitator lubr. instructions.

Note: Occasionally check gauge (10). The needle should return to zero with no pressure on the gauge.

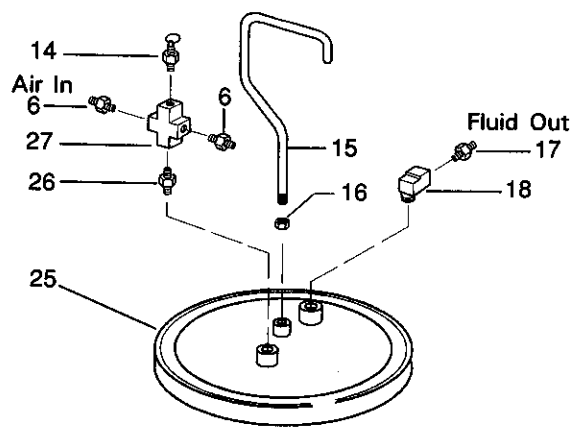

**PT-500-WB PRESSURE TANK**  
(Includes Ref. No. 1, 2 and 19 thru 24)

Ref. No.	Replacement Part No.	Description	Individual Parts Req.
1	PT-405	Tank Shell	1
2	PT-33-1	Lid Gasket, Santoprene	1
3	PT-408-WB	Lid, Stainless Steel	1
4	PT-418	Air Motor/Adapter Assy. (See Pg. 5 for Breakdown)	1
5	Purchase locally	Street Elbow 1/4" NPT (F) x 1/4" NPT (M)	5
6	H-2008	Nipple 1/4" NPT (M) x 1/4" NPS (M)	3
		PT-520-WB, 521-WB	3
		PT-510-WB, 511-WB	3
		PT-500-WB	2
6A	Purchase locally	Nipple 1/4" x 2" Galv. (PT-511-WB & 521-WB)	1
7	HA-57011	Hose Assembly	1
8	Purchase locally	Tee 1/4" NPT (M) x 1/4" NPT (F) x 1/4" NPT (F)	1
9	HAV-500	Air Adjusting Valve 1/4" NPS (F) x 1/4" NPS (M)	1
10	GA-333	Gauge (PT-510-WB, 520-WB)	1
		Gauge (PT-511-WB, 521-WB)	2
10A	Purchase locally	Pipe Plug 1/4" NPT(M) (PT-511-WB and 521-WB)	1
11	HAR-502	Regulator (All regulated models)	1
11A	HAR-505	Regulator (PT-511-WB & 521-WB)	1
12	SSP-30-ZN	90° Swivel Adapter 1/4" NPS (F) x 1/4" NPT (M)	1
13	SSP-2629-ZN	Branch Tee 1/4" NPT (F) x 1/4" NPS(F) x 1/4" NPT (M)	1
14	TIA-4380	Safety Valve	1
15	PT-32	Handle	1
16	Purchase locally	Hex Nut 3/8"-16	1
17	SSP-459	Nipple 3/8" NPT (M) x 3/8" NPT (M) S.S.	1
18	SSP-1939	Street Elbow 3/8" NPT (F) x 3/8" NPT (M) S.S.	1
19	SSF-5707-ZN	Thumb Screw	4
20	PT-406	Yoke Assembly	4
21	---	Cotter Pin, 3/32 x 1"	4
22	---	Hinge Pin	4
23	QMS-9-1	Fluid Tube, S.S.	1
24	PT-52-K10 or PT-52-K80	Tank Liner (Kit of 10 or 80)	1
25	PT-404-WB	Lid, Stainless Steel	1
26	Purchase locally	Nipple 1/4" NPT(M)	1
27	Purchase locally	Cross 1/4" NPT (F)	1

Suffixes -K2, K5, K10 designated kits of multiple parts.  
• Order KK-5009 Kit (Contains 4 each hinge & cotter pins)

**PT-510-WB PRESSURE TANK**  
(Includes Ref. No. 1, 2 and 19 thru 24)

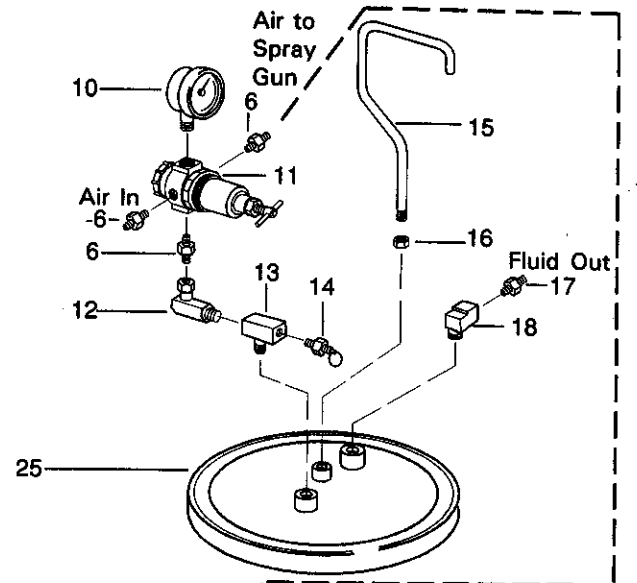

**PT-511-WB & PT-521-WB PRESSURE TANK**  
(Dual Regulation included with these models)

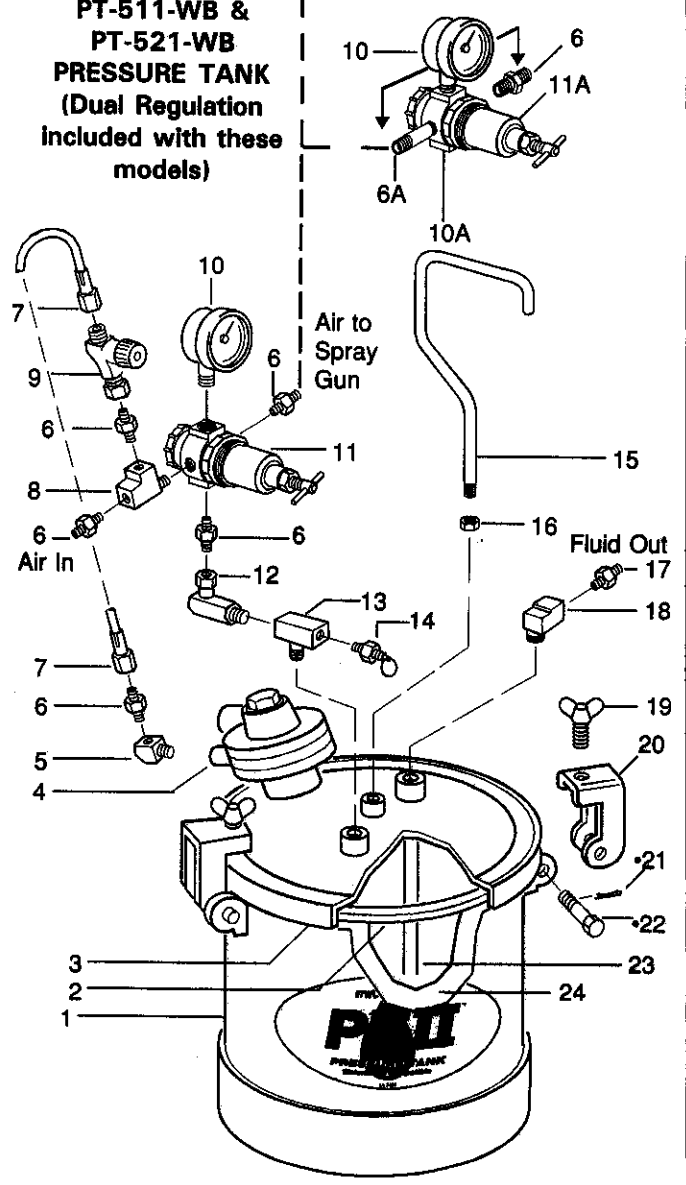

**PT-520-WB PRESSURE TANK WITH AGITATOR**

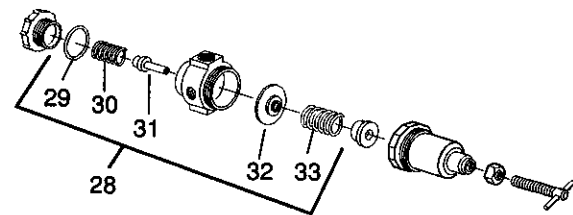
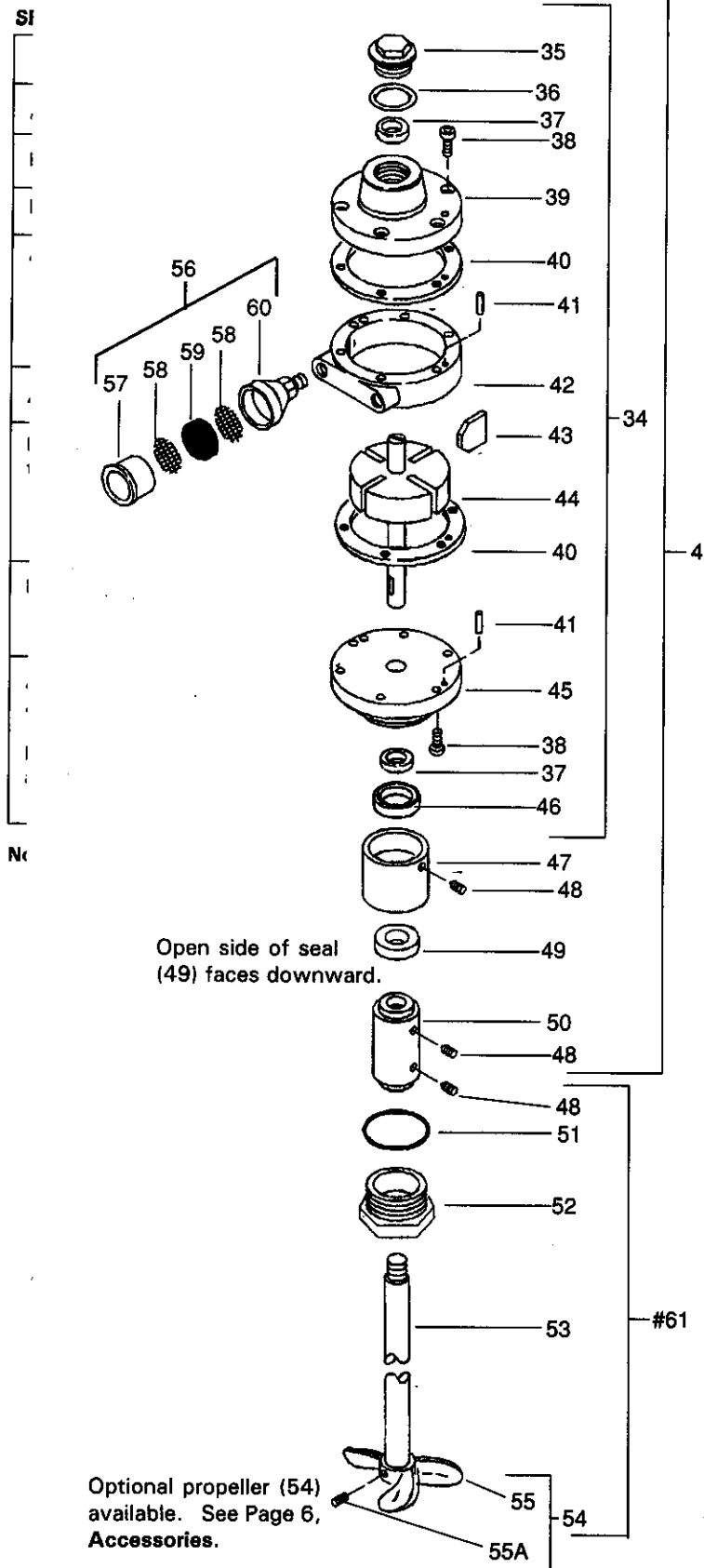

**HAR-502, 505 REGULATOR (Ref. No. 11)**

Ref. No.	Replacement Part No.	Description	Individual Parts Req.
28	KK-4139-3	Repair Kit	1
29	---	"O Ring"	1
30	---	Spring	1
31	---	Disc Stem Assembly	1
32	---	Diaphragm Assembly	1
33	---	Spring	1
34	PT-410	Air Motor Assembly	1
35	QS-190	End Cap	1
*36	---	End Cap Gasket	1
37	PT-58	Bearing	2
38	Purchase locally	Screw (1/4"-28 x 1/2")	12
•39	---	Front Plate	1
*40	PT-59-K10	End Plate Gasket	2
41	QS-189-1-K10	Dowel Pin (Kit of 10)	4
•42	---	Body	1
*43	---	Vane	4
44	PT-57	Rotor Assembly	1
•45	---	End Plate	1
46	PT-56	Shaft Seal	1
47	PT-50	Air Motor Adapter	1
48	Purchase locally	Set Screw (1/4"-20 x 1/4")	4
49	KK-5041	Seal Assembly	1
50	QMS-453	Shaft Coupling Kit (Includes #48)	1
51	SSG-8096-K5	"O" Ring (Kit of 5)	1
52	PT-70	Adapter Nut	1
53	QMS-73	Shaft	1
54	QMS-448	Propeller Assy.	1
55	---	Propeller	1
55A	Purchase locally	Set Screw (1/4"-20 x 3/8" S.S.)	1
56	350-401	Muffler Assembly	1
57	---	Body	1
+ 58	---	Screen	2
+ *59	---	Felt	1
60	---	Cap	1
#61	PT-419	Agitator Shaft Kit	1

**PT-418 Air Motor/Adapter Assembly (Ref. No. 4)**  
(Includes Ref. Nos. 34, 47, 48, 49 & 50)

**#PT-419 Agitator Shaft Assembly not included with PT-418 Assembly. Must be ordered separately.**

- Parts included in PT-410 Air Motor Assembly.
- \* Parts included in KK-5001-1 Air Motor Repair Kit.
- + Ref. No. (58) 2 ea. & Ref. No. (59) 4 ea. included in KK-5006 Strainer Screen & Felt Kit.

**ACCESSORIES**

**PT-52-K10 & PT-52-K80 Liner.** A molded polyethylene tank liner to reduce tank clean up time. The liner is made of tough, durable, leakproof polyethylene and can be re-used. May be used with all materials that are compatible with polyethylene. (Available in packages of 10 and 80 only.)



**PT-413 Air Regulator Kit.** Used to convert single regulated tanks (fluid only), to dual regulation (fluid and air). Used with portable air compressors or with air lines when no other means (air transformers or regulators) of air pressure regulation is available.

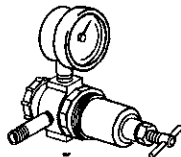

**Ball Valves.** VA-542 air inlet shut-off valve. To install, remove the H-2008 nipple.  
**VA-527 S.S. fluid outlet shut-off valve.** To install, remove the SSP-459 adapter. Using these valves will simplify attachment of air and fluid hoses.



**QMS-79 Optional Propeller.** Used with light viscosity or waterborne materials where over-agitation may be a problem.



**HARG-510 Air Regulator.** Use to maintain nearly constant outlet pressure despite changes in inlet pressure and downstream flow.

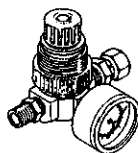

**HAV-501 Air Adjusting Valve.** Use to control air usage at gun.



**HFRL-508 Air Filter - Regulator, 50 CFM.** Designed to remove dirt, pipe scale and most liquid aerosol. It includes a 5 micron filter element.

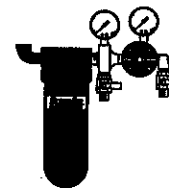

**SERVICE LITERATURE REVISIONS**

Refer to the following chart for Part No./Literature changes.

Part Number Changes			Literature Changes
Old Part Number	New Part Number	Interchangeability	
KK-4139-2 Repair Kit PT-65 End Cap	KK-4139-3 Repair Kit QS-190 End Cap	Directly Directly	1. Revised PT-511, 521 WB Dual Regulation Drawing on Page 4.

**WARRANTY**

This product is covered by DeVilbiss' 1 Year Limited Warranty. See SB-1-000 which is available upon request.

**DeVILBISS WORLDWIDE SALES AND SERVICE LISTING - [www.devilbiss.com](http://www.devilbiss.com)**

**INDUSTRIAL FINISHING**

DeVilbiss has authorized distributors throughout the world. **FOR TECHNICAL ASSISTANCE OR THE DISTRIBUTOR NEAREST YOU, CALL TOLL FREE 1-800-338-4448 (U.S.A. AND CANADA ONLY). FOR LOCAL CALLS, SEE LISTING BELOW.**

U.S./Canada Sales & Customer Service Office  
 GLENDALE HEIGHTS, IL 60139

Address  
 195 Internationale Blvd.

Telephone No.  
 (630) 237-5000  
 Toll Free Fax No. 1-877-790-6965

**AUTOMOTIVE REFINISHING**

DeVilbiss has authorized distributors throughout the world. For equipment, parts and service, check the Yellow Pages under "Automobile Body Shop Equipment and Supplies". **FOR TECHNICAL ASSISTANCE, CALL TOLL FREE 1-800-445-3988 (U.S.A. ONLY). FOR LOCAL CALLS, SEE LISTING BELOW.**

U.S. Customer Service Office  
 MAUMEE, OH 43537

Address  
 1724 Indian Wood Circle

Telephone No.  
 (419) 891-8100  
 Toll Free Fax No. 1-800-445-6643



An Illinois Tool Works Company